

Lab work for the seminaire "Energy Harvesting", part 1

Dimitri Galayko

1 Introduction

This lab is devoted to a study of conditioning circuits for capacitive transducer used for electromechanical energy conversion.

2 Introduction : Getting started with the simulation tool

We use the simulation tool LTspice to perform simulation. LTspice is a commercial version of the Spice simulator. LTspice allows to instantiate behavioural controlled voltage and current sources, and this allows a simulation of non-electrical blocks of mixed-signal systems, variable capacitors, etc.

3 Continuous conditioning circuit

3.1 Test of the variable capacitor model

The variable capacitance is implemented as a behavioural current source controlled by a voltage source, according to the formula.

$$i = Cvar \frac{dV}{dt} + V \frac{dCvar}{dt}, \quad (1)$$

where $Cvar$ is a *voltage* representing the instantaneous value of the capacitor, i and v are the current and voltage on the transducer. The $Cvar$ quantity is generated by a voltage controlled voltage source :

$$Cvar = \epsilon_0 \frac{S}{d0 - x} \quad (2)$$

where x is the voltage representing the time variation of the position of the mobile electrode :

$$x = X0 \sin(2\pi ft) \quad (3)$$

This model have four parameters S , d , $X0$ and f .

The netlist "test_capa_variable.cir" describes a continuous conditioning circuit given in fig. 1. You will need to modify the netlist in order to do the proposed exercices.

To test the model of the variable capacitor, we set the load resistance to a low value (e.g., 1 Ohms), and we measure current through the source. The parameters of the network are the following : $V_{res} = 10V$, $S = 10^{-4}m^2$, $d = 10\mu m$, the displacement is sinusoidal with amplitude $X_0 = 5\mu m$ and frequency $f = 100Hz$.

Perform a transient simulation for 1 seconds, and visualize the current flowing through the voltage source. Which is the amplitude of this current? Why there is a strong and short negative pulse at the beginning of the transient process?

Exercise. Given the parameters of the variable capacity and of the voltage source provided in the model, calculate the amplitude of the variable capacity current, and compare it with the amplitude given by the simulation.

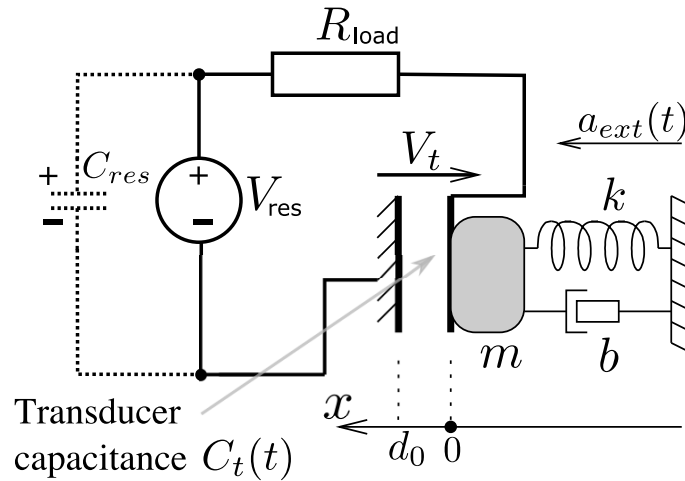

FIGURE 1 – Schematic of continuous conditioning circuit.

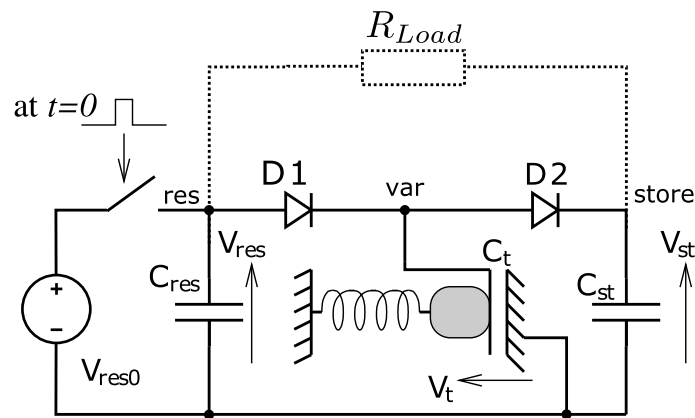

FIGURE 2 – Schematic of the charge pump.

3.2 Generation of electricity with a variable capacitor

We will now make the circuit autonomous by removing the power source V_{res} and by replacing it with a fixed capacitance $C_{res} = 1\mu\text{F}$, charged to 10 V. For this, (i) comment the voltage source and (ii) uncomment the line instantiating the fixed capacitor C_{res} . In order to pre-charge the capacitance, the parameter ic of the capacitor is set to 10.

With use of the command `.step`, perform a series of simulation by varying the resistance R from 1 MOhm to 30 MOhm with a step of 2 MOhm (uncomment the command "sweep" in the provided netlist). Observe the current in the resistor, the voltage on the variable capacitor and on the fixed capacitor. Conclude on electric power generated.

In order to find the optimal value of the resistance at which the power is maximal, calculate the average of the quantity V_{load}^2/Rl with the help of the command `measure`, and plot the curve "Power versus resistance".

To do it : after the simulation, right click on the netlist window, and open `.log` file with the pop-up menu. From the `.log` file, right click and from the pop-up menu, choose "plot step'ed .meas data".

Observe the evolution of states of the variable capacity axes " voltage - charge ". For that, modify the netlist so to make explicitly appeared the charge of the variable capacitor.

4 Charge pump

Now we will use the model of variable capacity to study the charge pump (fig. 2). The charge pump is modeled in the file "chargepump.cir".

In this circuit, the capacitor C_{res} is pre-charged to 5 Volts. You can change the initial charge of the

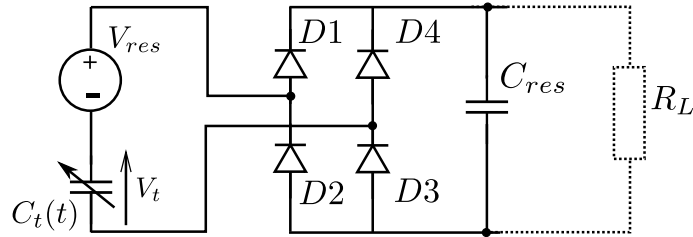

FIGURE 3 – Schematic of a double-wave rectifier used with pre-biased electrostatic transducers.

capacitor.

Run the transient simulation, and observe the evolution of the voltages and of the energy on the capacitors. Conclude about the optimal operation mode of the circuit.

– Which is the theoretical value of the saturation voltage of V_{store} ? Calculate it and compare with what you observe with simulations.

– Which is the theoretical value of the saturation voltage of V_{store} if $X_0 = 7\mu m$? Run the simulation and observe the result.

4.1 Q-V cycle

Display the quantity "charge" of the capacitor model and trace the state of the variable capacity in the Q-V axes .

4.2 Estimated Energy

Estimate theoretically the maximum power that the variable capacitor of the circuit *chargepump.cir* can produce, given the value of $V_{res} = 5V$ and frequency defined in this circuit. Compare with the maximum energy generation rate, obtained in simulation. Compare the levels of energy obtained for the amplitudes X_0 of $5\mu m$ and $7\mu m$.

4.3 A resistive flyback

Consider a load resistance R_{Load} between the nodes *res* and *store*, which implements a resistive flyback (fig. 2, dotted lines).

Calculate the value of the resistance required to maintain the circuit in the optimal mode (i.e., a maximum energy). Add this resistance to your netlist, and re-simulate the network.

5 Double wave rectifier with pre-biased capacitive transducer

We propose to write a netlist which models the circuit of fig. 3, which is often used with transducers pre-biased by the electret layer.

In order to do it, modify the netlist "chargepump.cir" which contains all necessary models. In this model, the capacitance C_{res} is initially discharged (its initial voltage is zero). Observe the evolution of the voltage on C_{res} , measure the value of the saturation voltage.

– Study the circuit and propose a theoretical formula giving the saturation voltage on the reservoir capacitor. Compare this value with what you obtained with simulations.

6 Bibliographie

D. Galayko et al., AMS modeling of controlled switch for design optimization of capacitive vibration energy harvester, BMAS2007 international conference, 2007, San José, CA

B. C. Yen, J. H. Lang, A variable-capacitance vibration-to-electric energy harvester, IEEE transactions on Circuits and Systems I : Regular Papers, vol. 53, pp. 288-295, February 2006