

Modèle Client-Serveur

1

3 couches

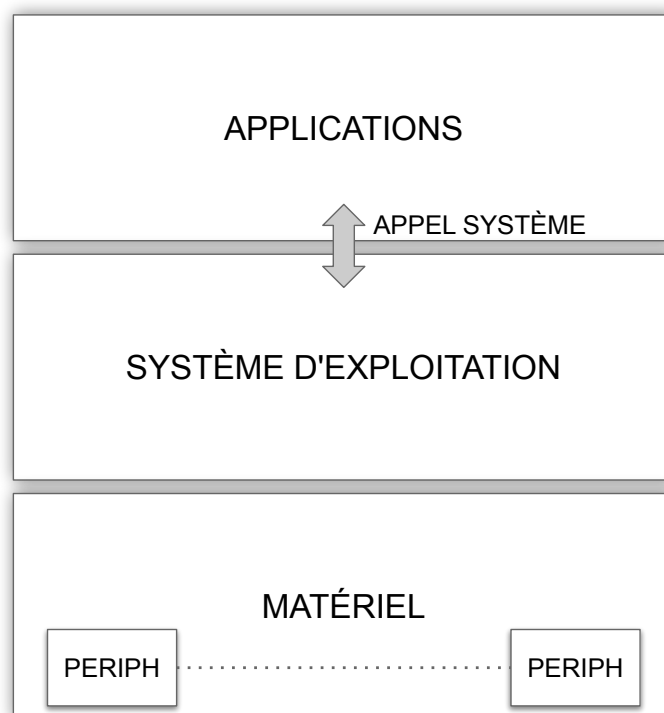

2

Appels Système Fondamentaux (user)

Dans UNIX, « tout est fichier »

⇒ Un périphérique est un fichier

```
int fd; char * pathname ; int flags;  
char buffer[100]; int len, actuel_len;
```

- `fd = open(pathname, flags);`
 - `actuel_len = read(fd, buffer, len);`
 - `actuel_len = write(fd, buffer, len);`
 - `close(fd);`
- longueur max
- longueur exacte

3

Accès Fichier

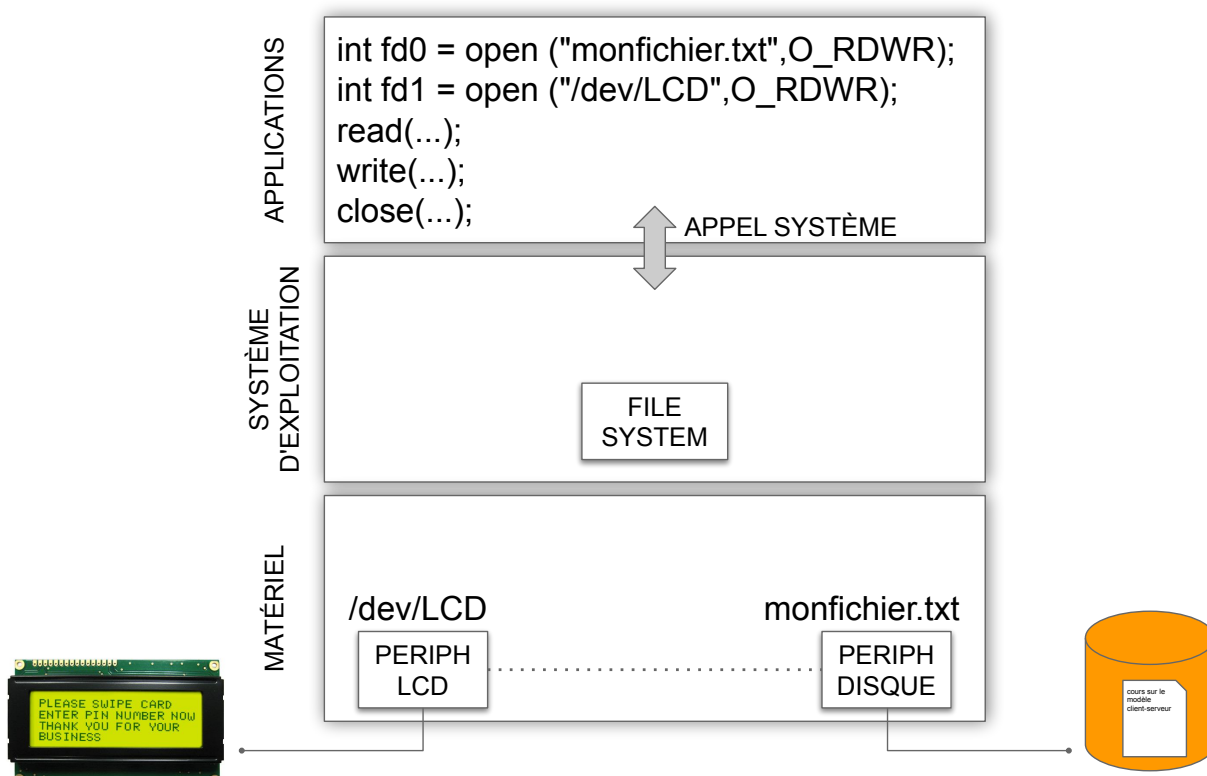

4

Accès Fichier

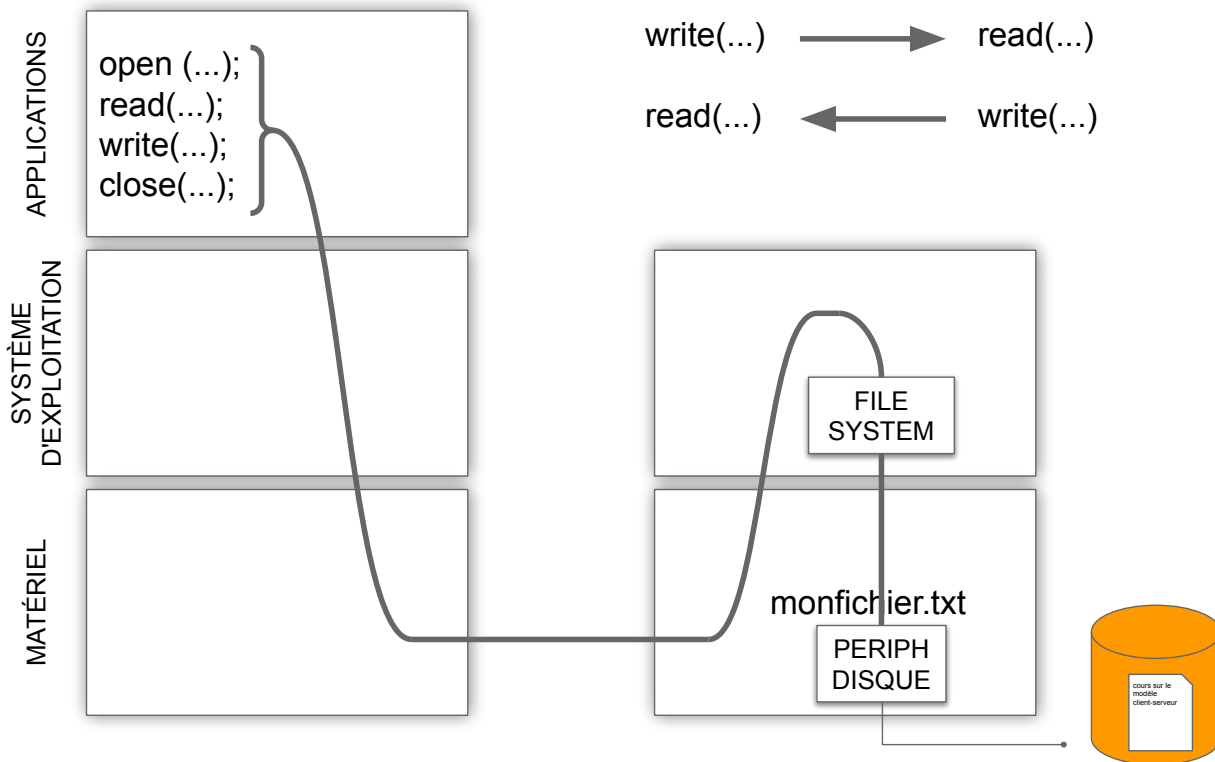

5

Modèle OSI – Modèle TCP/IP (unix)

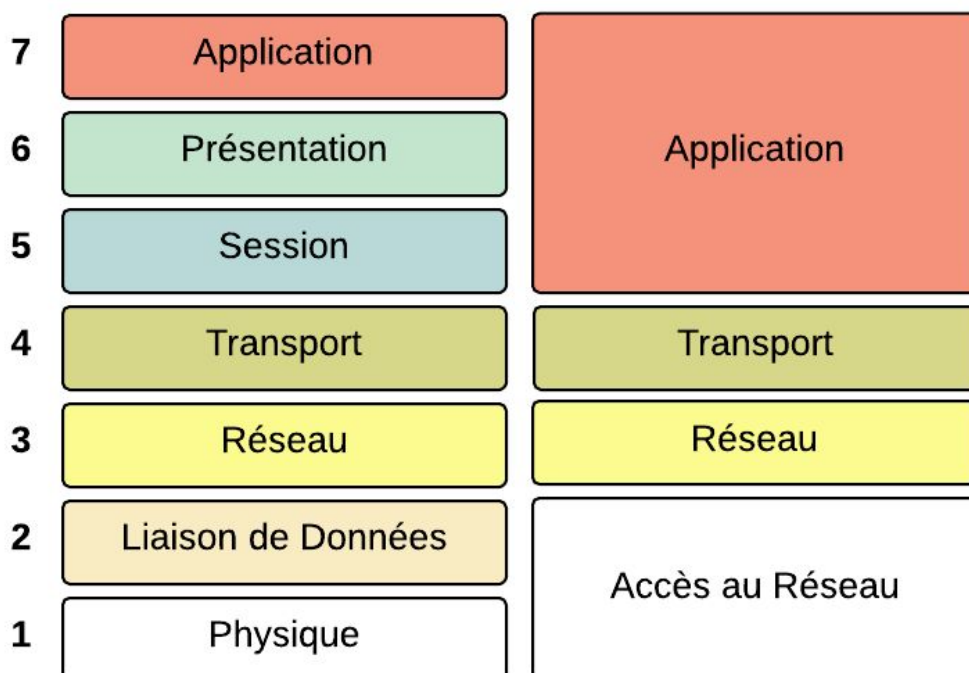

<https://juleshuynhvan.business.blog/2017/02/20/modele-osi-modele-tcpip/>

6

Echange Client – Serveur

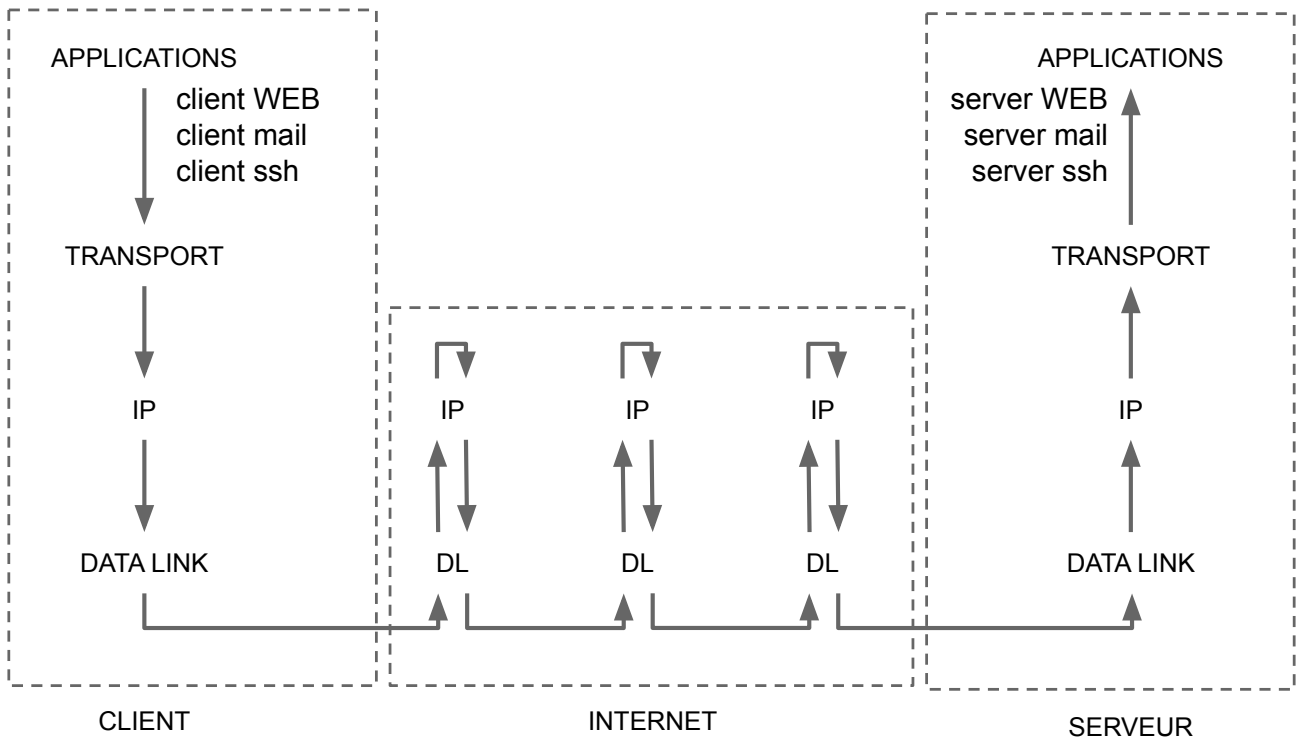

7

SERVICES

Un serveur **rend** un service
Un client **demande** un service

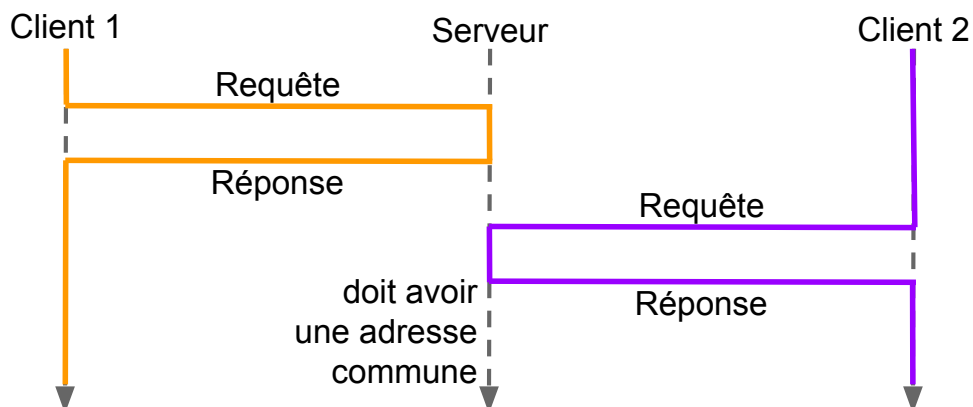
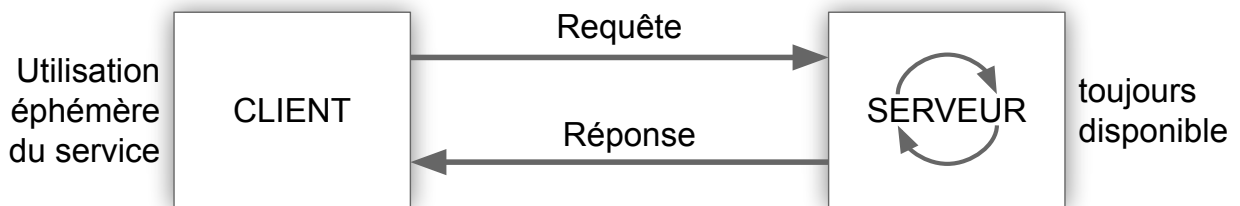

8

TCP/IP

Network Topology

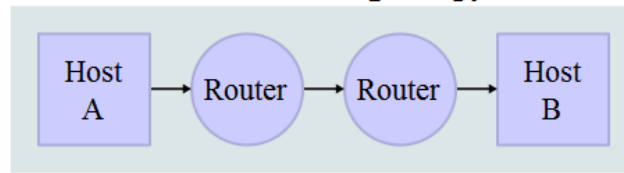

Data Flow

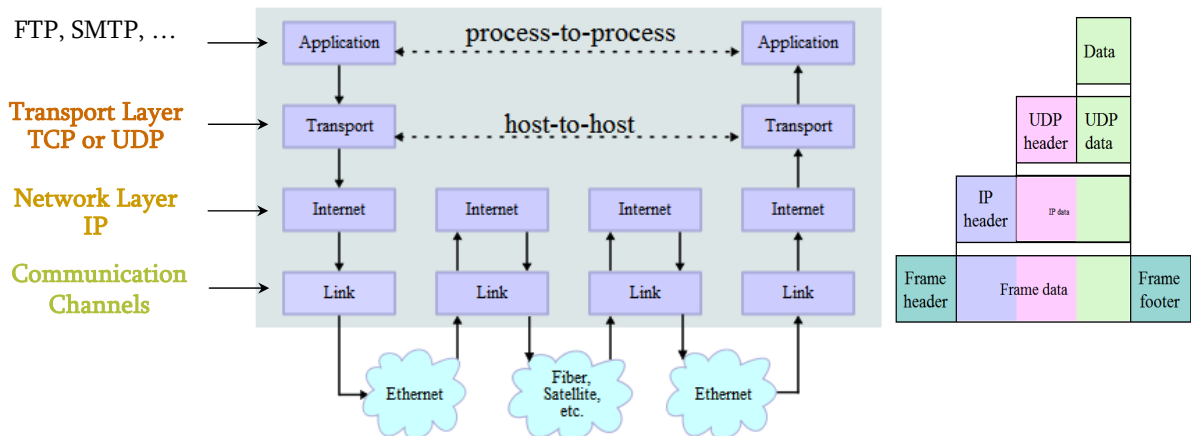

* image is taken from "http://en.wikipedia.org/wiki/TCP/IP_model"

Internet Protocol (IP)

- provides a **datagram** service
 - packets are handled and delivered independently
- **best-effort** protocol
 - may lose, reorder or duplicate packets
- each packet must contain an **IP address** of its destination



TCP vs UDP

- Both use **port numbers**
 - application-specific construct serving as a communication endpoint
 - 16-bit unsigned integer, thus ranging from 0 to 65535
 - ☞ to provide **end-to-end** transport
- UDP: User Datagram Protocol
 - no acknowledgements
 - no retransmissions
 - out of order, duplicates possible
 - connectionless, i.e., app indicates destination for each packet
- TCP: Transmission Control Protocol
 - reliable **byte-stream channel** (in order, all arrive, no duplicates)
 - similar to file I/O
 - flow control
 - connection-oriented
 - bidirectional

Berkley Sockets

- Universally known as **Sockets**
- It is an abstraction through which an application may send and receive data
- Provide **generic access** to interprocess communication services
 - e.g. IPX/SPX, Appletalk, TCP/IP
- Standard API for networking

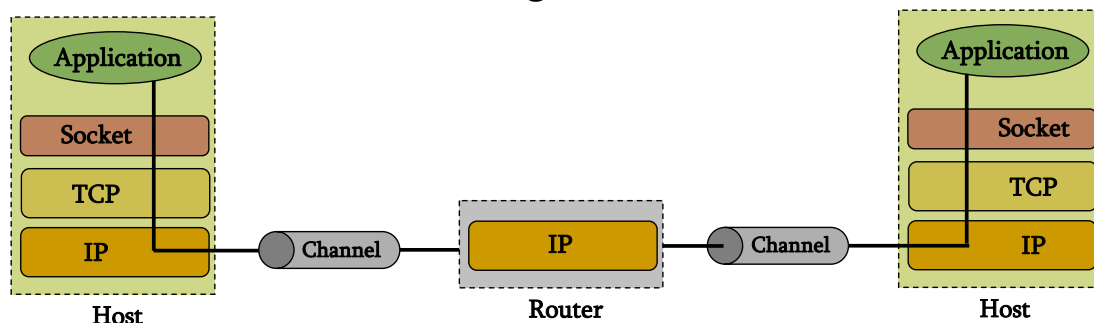

Sockets

- Uniquely identified by
 - an internet address
 - an end-to-end protocol (e.g. TCP or UDP)
 - a port number
- Two types of (TCP/IP) sockets
 - **Stream** sockets (e.g. uses TCP)
 - provide reliable byte-stream service
 - **Datagram** sockets (e.g. uses UDP)
 - provide best-effort datagram service
 - messages up to 65.500 bytes
- Socket extend the convectional UNIX I/O facilities
 - file descriptors for network communication
 - extended the read and write system calls

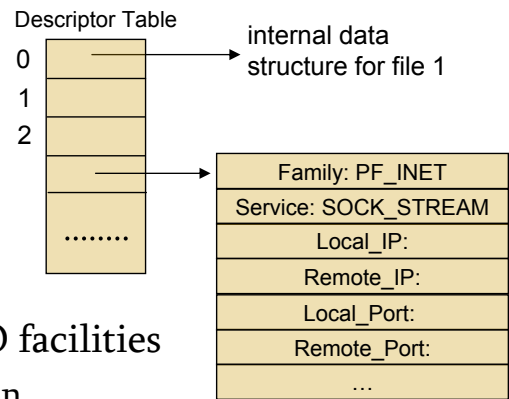

Sockets

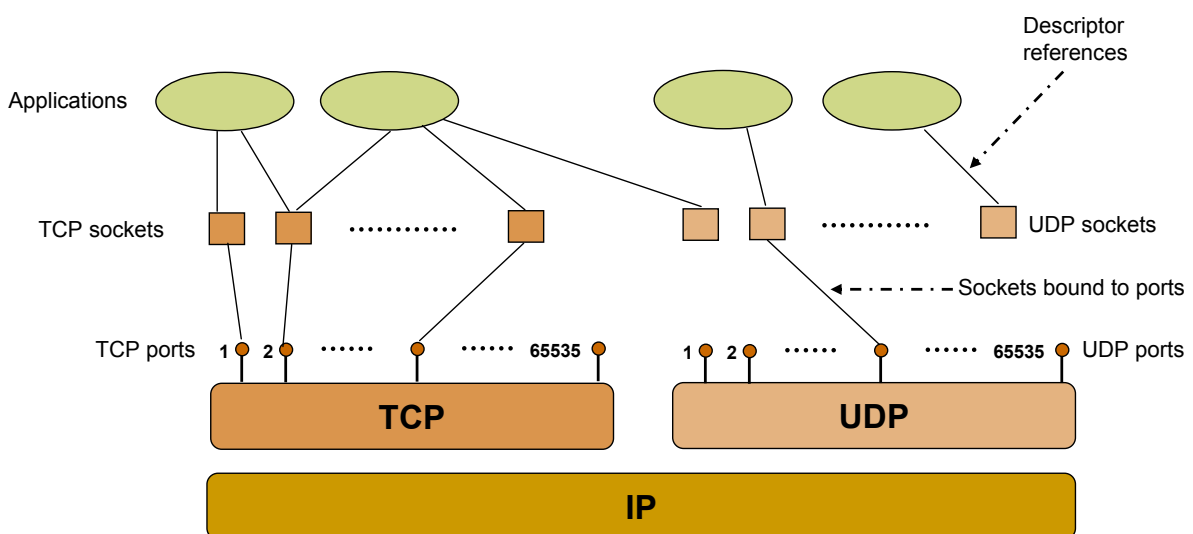

Client-Server communication

■ Server

- passively waits for and responds to clients
- **passive** socket

■ Client

- initiates the communication
- must know the address and the port of the server
- **active** socket

Sockets - Procedures

Primitive	Meaning
Socket	Create a new communication endpoint
Bind	Attach a local address to a socket
Listen	Announce willingness to accept connections
Accept	Block caller until a connection request arrives
Connect	Actively attempt to establish a connection
Send	Send some data over the connection
Receive	Receive some data over the connection
Close	Release the connection

Client - Server Communication - Unix

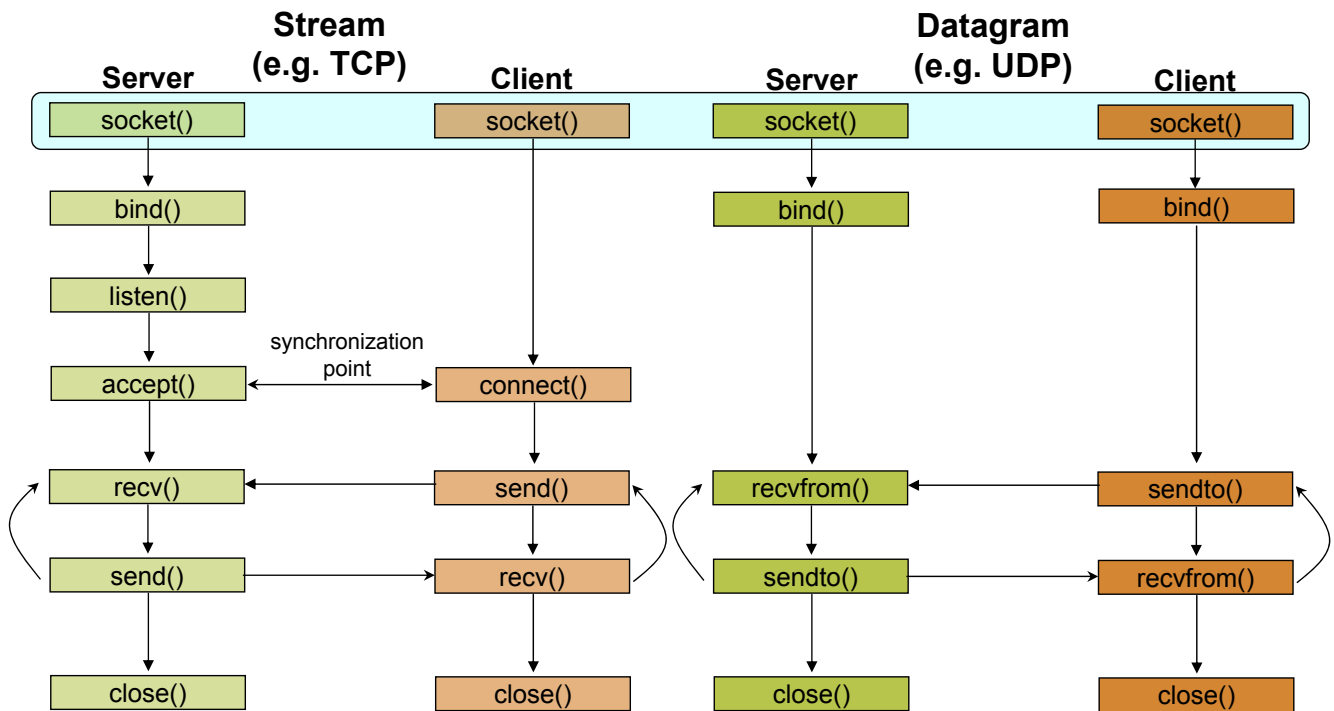

Socket creation in C: `socket()`

- `int sockid = socket(family, type, protocol);`
 - **sockid**: socket descriptor, an integer (like a file-handle)
 - **family**: integer, communication domain, e.g.,
 - PF_INET, IPv4 protocols, Internet addresses (typically used)
 - PF_UNIX, Local communication, File addresses
 - **type**: communication type
 - SOCK_STREAM - reliable, 2-way, connection-based service
 - SOCK_DGRAM - unreliable, connectionless, messages of maximum length
 - **protocol**: specifies protocol
 - IPPROTO_TCP IPPROTO_UDP
 - usually set to 0 (i.e., use default protocol)
 - upon failure returns -1
- 👉 NOTE: socket call does not specify where data will be coming from, nor where it will be going to – it just creates the interface!

Assign address to socket: `bind()`

- associates and reserves a port for use by the socket
- `int status = bind(sockid, &addrport, size);`
 - **sockid**: integer, socket descriptor
 - **addrport**: struct `sockaddr`, the (IP) address and port of the machine
 - for TCP/IP server, internet address is usually set to `INADDR_ANY`, i.e., chooses any incoming interface
 - **size**: the size (in bytes) of the `addrport` structure
 - **status**: upon failure -1 is returned

`bind()` - Example with TCP

```
int sockid;
struct sockaddr_in addrport;
sockid = socket(PF_INET, SOCK_STREAM, 0);

addrport.sin_family = AF_INET;
addrport.sin_port = htons(5100);
addrport.sin_addr.s_addr = htonl(INADDR_ANY);
if(bind(sockid, (struct sockaddr *) &addrport, sizeof(addrport)) != -1) {
    ...}
```

Assign address to socket: `bind()`

- Instructs TCP protocol implementation to listen for connections
- `int status = listen(sockid, queueLimit);`
 - `sockid`: integer, socket descriptor
 - `queueLen`: integer, # of active participants that can “wait” for a connection
 - `status`: 0 if listening, -1 if error
- `listen()` is **non-blocking**: returns immediately
- The listening socket (`sockid`)
 - is never used for sending and receiving
 - is used by the server only as a way to get new sockets

Establish Connection: `connect()`

- The client establishes a connection with the server by calling `connect()`
- `int status = connect(sockid, &foreignAddr, addrlen);`
 - `sockid`: integer, socket to be used in connection
 - `foreignAddr`: struct `sockaddr`: address of the passive participant
 - `addrlen`: integer, `sizeof(name)`
 - `status`: 0 if successful connect, -1 otherwise
- `connect()` is **blocking**

Incoming Connection: `accept()`

- The server gets a socket for an incoming client connection by calling `accept()`
- `int s = accept(sockid, &clientAddr, &addrLen);`
 - `s`: integer, the new socket (used for data-transfer)
 - `sockid`: integer, the orig. socket (being listened on)
 - `clientAddr`: struct `sockaddr`, address of the active participant
 - filled in upon return
 - `addrLen`: `sizeof(clientAddr)`: value/result parameter
 - must be set appropriately before call
 - adjusted upon return
- `accept()`
 - is **blocking**: waits for connection before returning
 - dequeues the next connection on the queue for socket (`sockid`)

Exchanging data with stream socket

- `int count = send(sockid, msg, msgLen, flags);`
 - `msg`: `const void[]`, message to be transmitted
 - `msgLen`: integer, length of message (in bytes) to transmit
 - `flags`: integer, special options, usually just 0
 - `count`: # bytes transmitted (-1 if error)
- `int count = recv(sockid, recvBuf, bufLen, flags);`
 - `recvBuf`: `void[]`, stores received bytes
 - `bufLen`: # bytes received
 - `flags`: integer, special options, usually just 0
 - `count`: # bytes received (-1 if error)
- Calls are **blocking**
 - returns only after data is sent / received

Socket close in C: `close()`

- When finished using a socket, the socket should be closed
- `status = close(sockid);`
 - **sockid**: the file descriptor (socket being closed)
 - **status**: 0 if successful, -1 if error
- Closing a socket
 - closes a connection (for stream socket)
 - frees up the port used by the socket

MQTT

Introduction MQTT

- Un protocole de messagerie basé sur TCP-IP.
- Développé par IBM en 1999.
- Protocole léger de messagerie machines to machines (déconnexions fréquentes)
- Transmission de données très faible bande passante.
- Adapté aux réseaux sans fil.
- Faible consommation énergétique.

Glossaire

- Broker Distribue les informations aux clients intéressés
- Client Connecté au Broker pour envoyer ou recevoir des informations.
- Topic Nom du message. Les clients publient, ou souscrivent à un Topic.
- Publish Envoi d'informations par un client au Broker qui les redistribue aux clients abonnés au Topic
- Subscribe Abonnement à un Topic pour recevoir les messages publiés
Désabonnement possible
- QoS Qualité de service.
On peut spécifier une qualité de service au Broker avec une valeur entre 0 et 2.
 - 0 au plus une seule fois sans qu'un accusé de réception
 - 1 au moins une fois, message envoyé plusieurs fois jusqu'à la réception de l'accusé de réception
 - 2 spécifie exactement une fois, Clients expéditeurs et destinataires ont la garantie d'une seule copie du message

Principe de MQTT

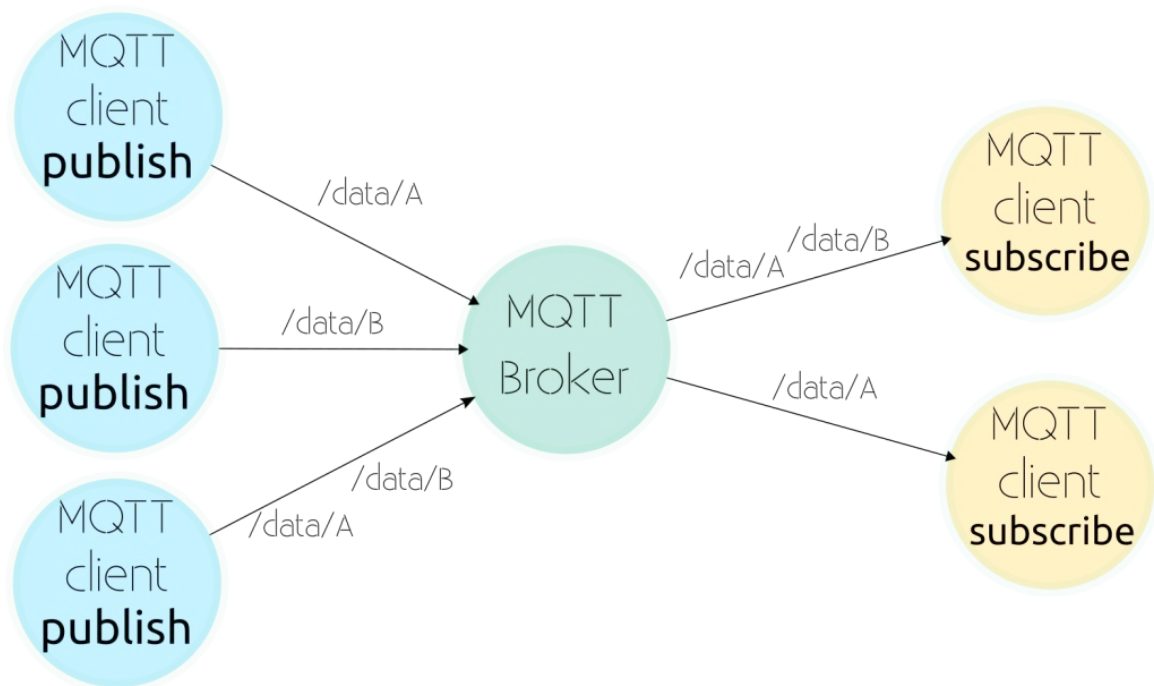

source : <https://openestio/2018/05/22/mqtt-un-protocole-de-communication-pour-vos-objets-connectes/>

En TME

Programmer une application de vote client-serveur et..